



The LPT-A is a full featured, single sensor, analog transmitter available with a wide range of sensors and sensor types including electrochemical, solid state and catalytic. Operating as an analog transmitter or a stand-alone fixed system, the LPT-A offers 3-wire VDC or 4-wire VAC power, jumper selectable 4 - 20 mA or 0 - 10 VDC analog output, one dry contact relay, thermal resetting fuses, temperature compensation, back lit LCD display and audible alarm, all in a RoHS compliant package. It comes standard with a water / dust tight, corrosion resistant ABS / polycarbonate enclosure with a hinged, secured door. With the optional splash guard installed, the enclosure is IP54 rated and ideal for use in water spray or wash down applications.

Automated calibration and other maintenance procedures are simple and easily performed in the field. For parking garage applications, our proprietary Calibration Extending Firmware (CEF) takes into account the aging of the sensor so that less frequent calibrations are required. For use in non-hazardous, non-explosion rated commercial and light industrial applications.

KEY FEATURES

- » Single channel, with an internal electrochemical sensor or catalytic for combustibles (internal or remote) or solid state for refrigerants (internal) or PID TVOC (remote)
- » One 2A SPDT dry contact relay
- » Internal audible alarm
- » LCD display (with user selectable function)
- » Linear 4 - 20 mA or 0 - 10 volt output signal
- » 3-wire VDC or 4-wire VAC power
- » 24 volt DC or AC power (nominal)
- » Optional heater for cold environment applications
- » Standard water / dust tight, corrosion resistant enclosure (drip proof); IP54 rated with optional splash guard installed.

APPLICATIONS

- » Parking Garages/Car Parks
- » Vehicle Repair Shops
- » Ice Arenas
- » Ice Cleaning Machine Rooms
- » Commercial Indoor Swimming Pools
- » Manufacturing Plants
- » Maintenance Facilities
- » Cold Storage / Freezer Rooms
- » Chiller Rooms
- » ... and many more

ANALOG GAS DETECTORS DATASHEET

LPT-A Analog Transmitter

TECHNICAL DRAWING

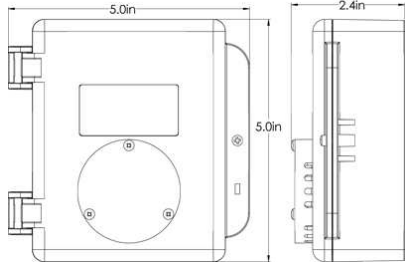

Note: Drawings above are shown with an optional splash guard. Without splash guard, thickness of unit is 53.34 mm (2.1 inches).

WIRING

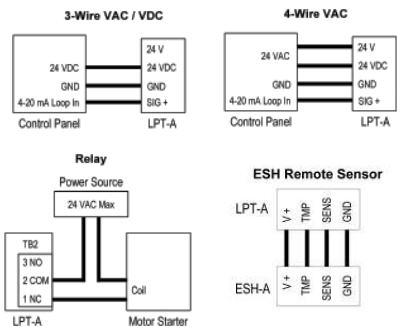

TECHNICAL SPECIFICATIONS

MECHANICAL	
Enclosure	ABS / Polycarbonate, IP54 rated with splash guard installed. Copper coated interior to reduce RF interference.
Weight	400 g (14 oz)
Size	127 x 127 x 53 mm (5.0 x 5.0 x 2.1 inches)

USER INTERFACE	
Display	Graphic LCD, grey border
Magnetic Sensors	Using a magnetic wand, initiate calibration without opening the enclosure

INPUT / OUTPUT	
Output	<ul style="list-style-type: none"> - Linear 4 - 20 mA analog - Maximum 216 Ω load (wiring plus termination resistor) @ 12 VDC - Maximum 316 Ω load (wiring plus termination resistor) @ 12 VAC - Voltage 0 - 10 volt - Minimum 1k ohm load

TECHNICAL SPECIFICATIONS continued

Relay	1 SPDT dry contact, rated 30 volts, 2 amps max
Audible Alarm	Standard internal buzzer; enable/disable

ELECTRICAL

Power Requirement	3-wire mode 16-30 VDC, 3 W, Class 2 4-wire mode 12-27 VAC, 50-60 Hz, 3 VA, Class 2
Wiring	-VDC (or ground referenced AC) three conductor shielded 18 awg stranded -VAC four conductor shielded 18 awg stranded
Fuses	Thermal, resetting

ENVIRONMENTAL

Operating Temperature	-20°C to 40°C (-4°F to 104°F), lower temperature option available
Humidity	15 - 90% RH non-condensing

CERTIFICATION

Conforms to: CSA-C22.2 No. 205-M1983 (R2009), UL508 (Edition 17):2007
 Conforms to: EMC Directive 2004/108/EC, EN 50270:2006, Type 1, EN61010
 Conforms to: FCC. This device complies with Part 15 of the FCC Rules.

PRODUCT CODES

Internal Electrochemical Sensors	Lifespan
LPT-A-NH3	Ammonia (NH ₃) sensor (0 - 500 ppm) 2 yrs
LPT-A-COA	Carbon Monoxide (CO) sensor (0 - 200 ppm) 3 yrs
LPT-A-COB	Carbon Monoxide (CO) sensor (0 - 200 ppm) 6 yrs
LPT-A-CLO2	Chlorine Dioxide (ClO ₂) sensor (0 - 1 ppm) 2 yrs
LPT-A-CL2	Chlorine (Cl ₂) sensor (0 - 5 ppm) 3 yrs
LPT-A-C2H4	Ethylene (C ₂ H ₄) sensor (0 - 200 ppm) 2 yrs
LPT-A-EETO	Ethylene Oxide (C ₂ H ₄ O) sensor (0 - 20 ppm) 2 yrs
LPT-A-F2	Fluorine (F ₂) sensor (0 - 1 ppm) 1-2 yrs
LPT-A-CH2O	Formaldehyde (CH ₂ O) sensor (0 - 5 ppm) 2 yrs
LPT-A-EH2	Hydrogen (H ₂) sensor (0 - 2,000 ppm) 2 yrs
LPT-A-H2S	Hydrogen Sulphide (H ₂ S) sensor (0 - 50 ppm) 2+ yrs
LPT-A-H2SB	Hydrogen Sulphide (H ₂ S) sensor (0 - 50 ppm) 5+ yrs
LPT-A-HCL	Hydrogen Chloride (HCl) sensor (0 - 30 ppm) 2 yrs
LPT-A-HCN	Hydrogen Cyanide (HCN) sensor (0 - 30 ppm) 2 yrs
LPT-A-HF	Hydrogen Fluoride (HF) sensor (0 - 10 ppm) 1-2 yrs
LPT-A-NO	Nitric Oxide (NO) sensor (0 - 100 ppm) 2 yrs
LPT-A-NO2A	Nitrogen Dioxide (NO ₂) sensor (0 - 10 ppm) 3 yrs
LPT-A-NO2B	Nitrogen Dioxide (NO ₂) sensor (0 - 10 ppm) 6 yrs
LPT-A-O2	Oxygen (O ₂) sensor (0 - 25% volume) 3 yrs
LPT-A-O3	Ozone (O ₃) sensor (0 - 2 ppm) 2 yrs
LPT-A-PH3	Phosphine (PH ₃) sensor (0 - 5 ppm) 2 yrs
LPT-A-SiH4	Silane (SiH ₄) sensor (0 - 20 ppm) 2 yrs
LPT-A-SO2	Sulphur Dioxide (SO ₂) sensor (0 - 20 ppm) 2+ yrs

PRODUCT CODES continued

Internal Solid State Sensors	Lifespan
LPT-A-SR22	Refrigerants (R22) sensor (0 - 2,000 ppm) 5 yrs
LPT-A-SR134A	Refrigerants (R134A) sensor (0 - 2,000 ppm) 5 yrs
LPT-A-SR402A	Refrigerants (R402A) sensor (0 - 2,000 ppm) 5 yrs
LPT-A-SR404A	Refrigerants (R404A) sensor (0 - 2,000 ppm) 5 yrs
LPT-A-SR407C	Refrigerants (R407C) sensor (0 - 2,000 ppm) 5 yrs
LPT-A-SR410A	Refrigerants (R410A) sensor (0 - 2,000 ppm) 5 yrs
LPT-A-SR422D	Refrigerants (R422D) sensor (0 - 2,000 ppm) 5 yrs
LPT-A-SR438A	Refrigerants (R438A) sensor (0 - 2,000 ppm) 5 yrs
LPT-A-SR507A	Refrigerants (R507A) sensor (0 - 2,000 ppm) 5 yrs
LPT-A-STVOC	TVOCs sensor (0 - 500 ppm) 5 yrs

Internal Catalytic Sensors	Lifespan
LPT-A-CH2-100	Hydrogen (H ₂) sensor (0 - 100% LEL) 5 yrs
LPT-A-CCH4-100	Methane (CH ₄) sensor (0 - 100% LEL) 5 yrs
LPT-A-C3H8-100	Propane (C ₃ H ₈) sensor (0 - 100% LEL) 5 yrs

ESH-A Remote PID Sensors	Lifespan
Part number is LPT-A-R + ESH-A part number listed below	
ESH-A-SPL	TVOC PID sensor (0 - 30 ppm) **
ESH-A-SPH	TVOC PID sensor (0 - 300 ppm) **

ESH-A Remote Catalytic Sensors	Lifespan
ESH-A-CH2-100	Hydrogen (H ₂) sensor (0 - 100% LEL) 5 yrs
ESH-A-CCH4-100	Methane (CH ₄) sensor (0 - 100% LEL) 5 yrs
ESH-A-C3H8-100	Propane (C ₃ H ₈) sensor (0 - 100% LEL) 5 yrs

ESH-A Remote Infrared Sensors	Lifespan
ESH-A-JET	Propane (C ₃ H ₈) sensor (0 - 100% LEL) 8 yrs

** usage and application dependant

OPTIONS (Factory installed) Add at the end of the "Part Number" above.

H	Internal heater for cold environment applications down to -40°C / 40°F
S	Splash guard (not available for O ₂ , HCl, or Cl ₂ sensors)

ACCESSORIES

CET-SGC	Calibration clip for splash guard
CET-715A-CK1	Calibration Kit for 17, 34, 58, 74, 100 L cylinders, 0.5 LPM flow regulator & adapter to fit 17 L cylinder
SCS-8000-RSG	Metal protective guard, small, 16 gauge, galvanized metal guards for transmitters

